

FORD 8-FT & 9-FT CRANEMASTER DIMENSIONS

Last Update: 02/05/2015

STANDARD OPEN-TOP VERTICAL SERIES

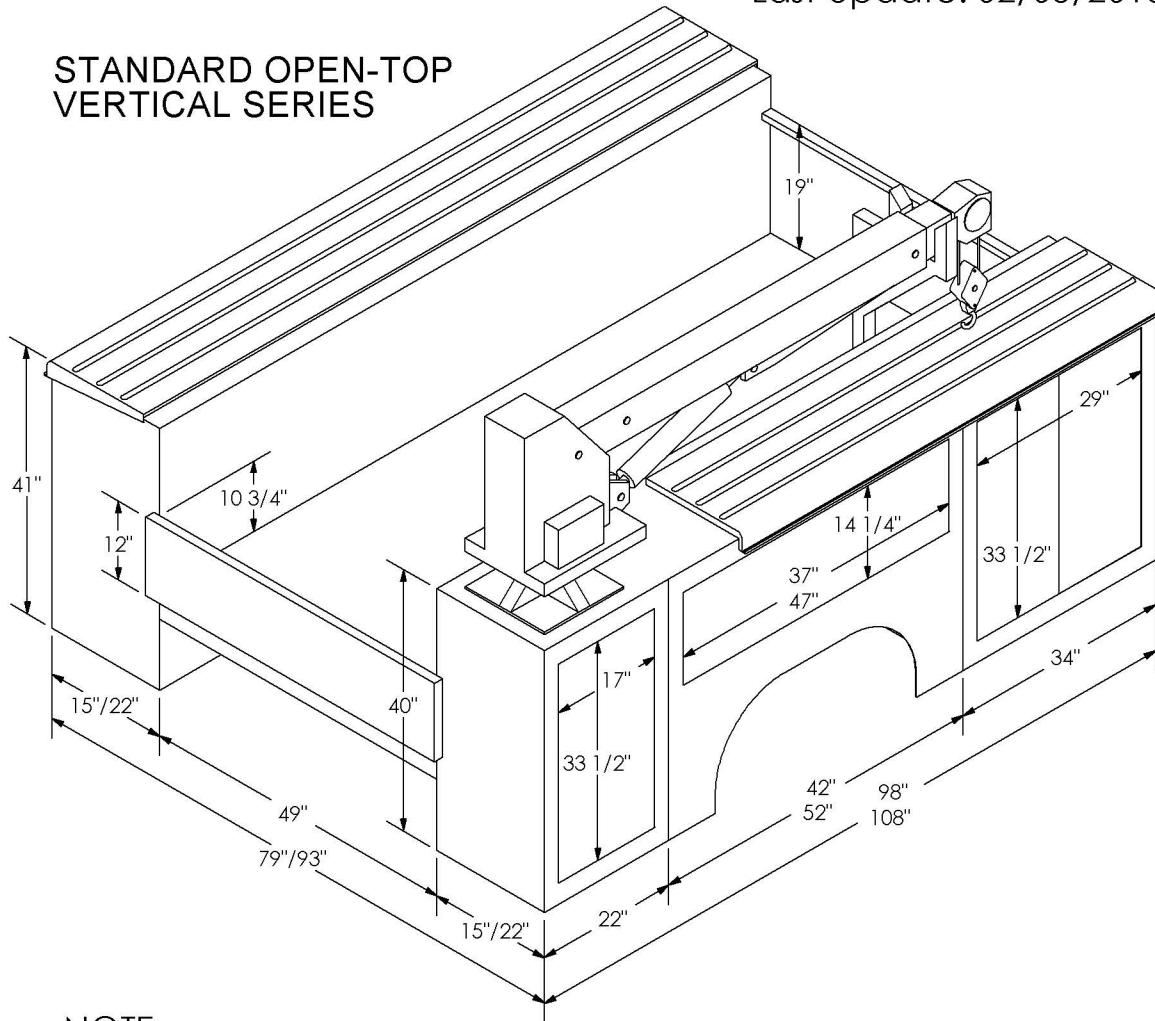

CLOSED-TOP MODEL

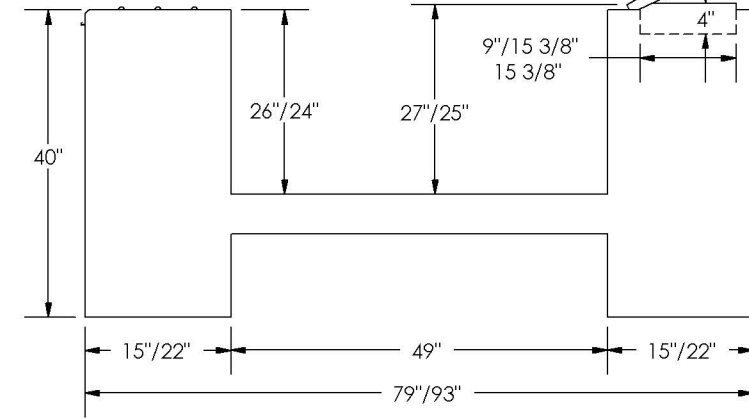

OPEN-TOP MODEL

NOTE:

- 1) DOOR COMPARTMENT DIMENSIONS ARE THE CLEAR DOOR OPENING.
- 2) TOP DIMENSIONS ONLY APPLIES TO 8-FT BODIES, BOTTOM DIMENSIONS ONLY APPLIES TO 9-FT BODIES.
- 3) DIMENSIONS SHOWN WITH FORWARD SLASH ARE SRW / DRW.
- 4) BODY WITH REAR PLATFORM OPTION COMES STANDARD WITH A DROP-IN TAILGATE.