

Location of Harbor I.D. Labels

Harbor's Identification I.D. plate is a blue information plate identifying the service body.

For utility bodies the I.D. plate is located inside the upper front part of the front compartment. Usually on the street side. (See Fig. 1 below)

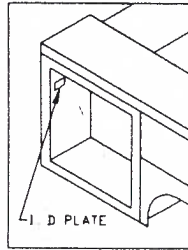

(Fig. 1) I.D. plate on Utility bodies

For flatbeds and dump bodies the I.D. plate is located on the street side of the front crossmember. (See Fig. 2 below)

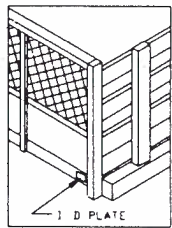

(Fig. 2) I.D. plate on Flatbeds & Dump Bodies

In addition to our I.D. plate, Harbor also provides a vehicle I.D. sticker. This sticker is a white sticker that provides important vehicle information such as GVWR and VIN information. For all vehicles the I.D. sticker is placed behind the driver seat on the back panel.



Harbor Truck Bodies Owner Manual

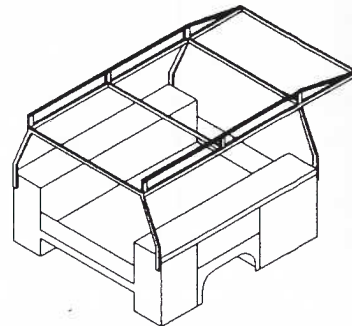

Harbor Truck Bodies

255 Voyager Ave. • Brea, California 92821
714-996-0411 • 800-433-9452 • FAX: 714-996-0695

INTRODUCTORY INFORMATION

Included in this owners manual is the following information:

Harbor's Commitment to You.....	1
Using this Guide.....	3
Maintenance Items.....	3
Replacement Parts.....	4
Harbor's Limited Three-Year Warranty.....	5
Location of Harbor I.D. Plate & Sticker...7	

Harbor's Commitment to You

At Harbor Truck Bodies, commitment means continuously trying to achieve the best result for our customers. This includes dedicating ourselves to learning what you want, having the determination to develop the products that suit your needs, and executing the production and sale of these products with care and attention to detail. In short, excellence means being the standard by which others are judged.

Our Commercial Order Guide shows all the new features and equipment we made standard in the 1996 model year alone. This just scratches the surface as to the changes we have made in sales, marketing and production to improve our ability to make top quality truck bodies.

Our Guiding Principles

- ◆ **You Are the Purpose of Everything We Do** - We are not doing you a favor by serving you... You are doing us a favor by giving us the opportunity to do so.

- ◆ **Quality Comes First** - For your satisfaction, the quality of our products and services must be our number one priority.
- ◆ **Integrity is Never Compromised** - Our conduct in the U.S. and worldwide (Harbor exports bodies to other countries too!) must be pursued in a manner that commands respect for its integrity.
- ◆ **Continuous Improvement is Essential to Our Continued Success** - We must strive to continually improve everything we do. In our service, in our competitiveness, and in our human relations.
- ◆ **Dealers, Distributors and Suppliers Are Partners** - We must maintain mutually beneficial relationships with our other business associates.
- ◆ **Employee Involvement is Our Way of Life** - We are a team and must treat each other with respect and trust.

Things to Know About Using this Owner's Manual

This Owner Manual was developed by Harbor Truck Bodies to provide you with maintenance information on your new service utility body, flatbed or stackbed. Included in this user manual are a select list of replacement parts. We have also included a copy of our Three-Year Limited Warranty and diagrams showing the location of our ID plates as well as re-caulking points.

Maintenance Items

◆ **Lube Points** - To maintain your service body there are a few points that should be kept lubricated every six months. (See figure below)

1. T-handle shafts (outside door)
2. Tailgate latches
3. Open top latches
4. Door rod mechanism (inside door)

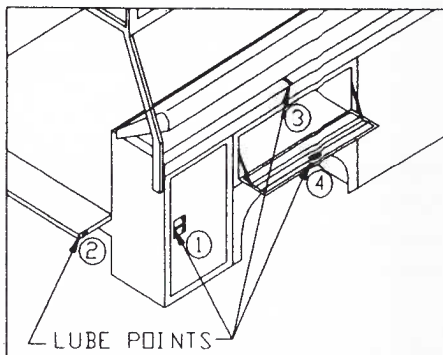

◆ **Re-Torque U-Bolts** - For those of you who have recently purchased a Flatbed, Stakebed or Standard Contractor Body, it is important to check and re-torque all U-bolts (80 foot-pounds each bolt) every six months.

◆ **Mounting Points** - For those of you who have recently purchased a service utility body, check all mounting points at least once annually. While they should not work loose, checking once a year is a smart pre-cautionary measure.

◆ **Re-Caulking** - Once a year, check the caulking in all service body compartments or boxes (For example along the solid lines shown in the diagram below). If the caulking is cracked, re-caulk those areas to prevent leaking using part # ZCLK caulking.

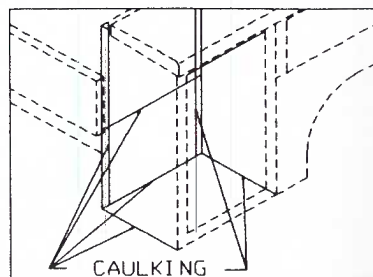

Replacement Parts

Harbor has developed a select list of replacement parts with part numbers for your convenience. These parts are the most likely to require replacement from heavy use or damage.

These parts are:

Part:	Part #:
1. Door Locks:	ZD75
2. Door Pocket:	ZD61
3. Tailgate Pocket:	ZF24
4. Hinge block: (Stainless)	ZD90
5. Tail light: (Red)	ZRB13
6. Back-up light: (White)	ZRB14
7. Clearance light: (Red)	ZRB15-R
(Amber)	RB15-A
8. Reflectors: (Red)	ZRB16-R
(Amber)	ZRB16-A
9. 3-Bar light: (Red)	ZRB11
10. Caulking (10.6 oz tube)	ZCLK
11. Door with pocket:	
	Call with Door Dimension
12. Door without pocket cutout:	
	Call with Door Dimension

To order replacement parts, please have the information available from the Customer Parts Order Form below and call our Parts Dept. at 1-800-433-9452

Customer Parts Order Form

Please have this information available before you call

Part Description: _____

Part No.: _____

Body Model No.: _____ Year: _____

Serial No.: _____

Chassis Make: _____ Year: _____

For door replacement

Door Inner Lining Dimensions:

L _____ X W _____

Harbor's Three-Year Limited Warranty

All truck bodies manufactured by Harbor Truck Bodies, Inc. (Harbor) are warranted against defects in factory supplied materials, paint and workmanship for a period of 3 years under normal use whichever comes first. Certain limitations apply.

Harbor will repair or replace, at its option, any factory-installed part that is defective in materials or workmanship under normal use. Warranty repairs will be made free of charge for parts and labor. Any needed part replacements will be made using new or remanufactured parts.

The warranty begins the date the product[s] is sold to the customer or the date it was first used

as a demonstrator or company vehicle, whichever occurs first (the so called "in-service-date.")

To assure that all warranty work meets the highest standards, Harbor reserves the right to perform all warranty in-house or through a Harbor distributor servicing center. **ALL WARRANTY REPAIR MUST BE APPROVED IN ADVANCE BY HARBOR TRUCK BODIES. PLEASE CALL 1-800-433-9452 FOR WARRANTY APPROVAL.** Any warranty claim for which repair is performed by truck dealers, customers or other third parties without Harbor's express written permission, shall void the warranty and subject the claim to rejection.

In the event a Harbor product was purchased through a Harbor distributor responsible for putting the finishing paint coat on the product, the distributor is directly responsible for the paint warranty coverage. Harbor's warranty coverage is limited to the primer coat only.

Harbor reserves the right to make changes at any time in truck bodies built and/or sold without incurring any obligation to make the same or similar changes on bodies previously built and/or sold.

This warranty is the only express warranty made by Harbor. Any implied warranty applicable to Harbor Truck Bodies is limited in duration to the length of this written warranty. Some states do not allow the exclusion or limitation of incidental or consequential damages or limitation of how long an implied warranty lasts, so the above mentioned limitations or exclusions may not apply.